

M&J VALVE

AN SPX BRAND

Installation, Operation & Maintenance Manual Ball-Trol™ Rotary Control Valve



M&J VALVE

AN SPX BRAND

M&J Valve
19191 Hempstead Highway
Houston, TX 77065
Telephone: 281-469-0550, Outside Texas (800) 231-3690
Fax: 281-894-1332
E-Mail: mjvalve@spx.com
Web Site: www.mandjvalve.com

SPX Flow Control - M&J Valve Facility, Houston, TX, is in conformance to ISO 9001:2000 for the design and manufacture of valves and related accessories under IAF scope Category 18.
APIQR resister number 0093.

SPX Process Equipment reserves the right to incorporate our latest design and material changes without notice or obligation. Design features, materials of construction and dimensional data, as described in this bulletin, are provided for your information only and should not be relied upon unless confirmed in writing. Certified drawings are available upon request.

Table of Contents

General Information.....	5
Installation.....	5
Unpacking	5
Handling	5
Installation	5
Operation.....	6
Normal Operation.....	6
Body Flushing and Draining.....	6
Maintenance.....	7
In-Line/In Service Maintenance	7
Major Overhaul.....	8
Exploded View and Parts List.....	10

Notes

M&J Valve Ball-Trol Control Valve Installation, Operation & Maintenance Manual

I. General Information

1. All M&J Ball-Trol control valves are bi-directional and may be installed for flow in either direction. M&J Ball-Trol control valves are intended for use in horizontal or vertical pipelines with the valve stem in any direction.
2. Valves are designed, manufactured, and tested in accordance with ANSI standards unless otherwise specified. Flanged end valve flanges are in accordance with ANSI B16.5 (24" and smaller) and MSS SP-44 (larger than 24").
3. Carbon steel weld end valves have end connections of ASTM A105 and are readily field weldable. End preparations match specified mating pipe bores.

4. Located on the body of the Ball-Trol, the nameplate (Fig. 1) provides applicable information including size, pressure class, materials, seals, pressure ratings and serial number. Reference to the serial number will expedite any request regarding your valve.

Figure 1

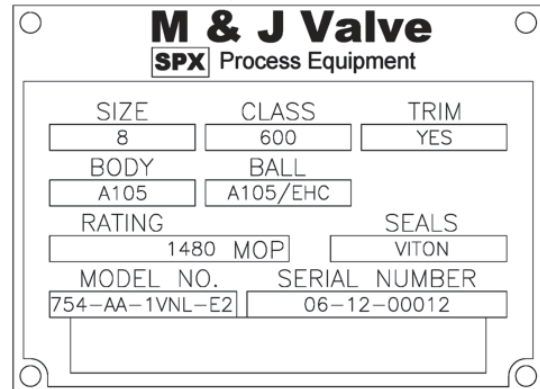

II. Installation

1.0 Unpacking

- 1.1 All valves should be inspected on receipt for lost components or damage.
- 1.2 Remove end connection protectors and thoroughly inspect interior of valve and end connections for damage or foreign material.
- 1.3 All Ball-Trol valves, other than fail-closed, are shipped in the open position to protect sealing surfaces.

2.0 Handling

- 2.1 Handling equipment appropriate for the valve weight is required.
- 2.2 The valve may be lifted by slings, end flanges, or the integral lift eyes provided on the valve. (Caution: Two (2) lift eyes are provided to balance the valve. Never lift valve using only one lift eye.)

3.0 Installation

- 3.1 Orient valve in piping to provide clearance and allow access to the actuator and controls.
- 3.2 Flanged end valves should be installed using the appropriate gasket (not supplied) and conventional flange installation procedures.
- 3.3 Weld end valves should be installed using qualified welders and weld procedures appropriate for the mating materials. Valve should be welded with the ball in the open position.
- 3.4 Prior to operating the valve from the open position, the piping should be thoroughly flushed to prevent foreign matter from damaging the sealing surfaces.
- 3.5 After installation and system testing, the valve should be drained to remove test fluid (See section III, 3.2).
- 3.6 Connect power and signal connections to their correct locations.

III. Operation

1. Normal Operation

1.1 M&J Ball-Trol control valves are factory set for the control operation specified. Instrument settings should be checked prior to operation.

2. Body Flushing and Draining

2.1 The M&J Ball-Trol valve is provided with two fittings on the body cavity. The pressure vent fitting (Fig. 2) and a pipe plug drain in the bottom of the body.

Note: Ball-Trol must be isolated via block valves before proceeding with the following steps.

2.2 Draining Procedure

2.2.1 Operate valve to the full-closed position.

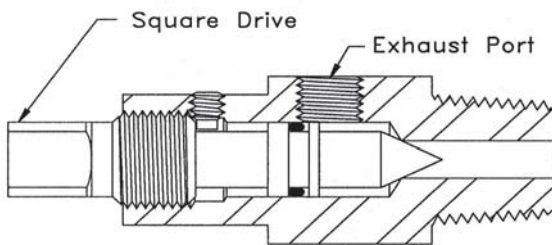

Figure 2

2.2.2 Using an appropriate wrench, turn the square drive on the vent fitting (Fig. 2) provided (located in the quadrant near the stem) to release the body cavity pressure. (Caution: Care should be taken to insure that the exhaust port on the side of the vent fitting is directed away from personnel). 1/8" NPT piping can be installed in the exhaust port of the vent valve to divert exhaust to a remote location/area.

2.2.3 Continue venting until body pressure reaches atmospheric pressure. (Note: Length of time required to vent the body will be proportional to the compressibility, the pressure, and the size of the valve.)

2.2.4 Once valve has been properly vented, remove the pipe plug from the bottom of the body. (Caution: Never remove any fitting without verifying that the fitting is not pressurized. Care should be taken to insure that the venting is directed away from personnel.) Take care not to lose the grounding spring under the pipe plug, and install when replacing the pipe plug.

2.3 Flushing Procedure

2.3.1 Once Draining steps 2.1 – 2.2.4 have been completed, the vent fitting can be removed to allow introduction of the flushing media.

IV. Maintenance

M&J Ball-Trol control valves should provide years of trouble-free operation without routine maintenance. Due to continuous throttling (etc.), the downstream seat will be exposed to more severe service than an on/off valve and may experience damage in some services. In the event of leakage, the following procedures may be used to insure continued operation of the valve.

1. In-Line/In Service Maintenance

The M&J Ball-Trol has three (3) stem seals: The inner backseated stem gasket, the inner stem seal and the outer stem seal.

1.1 The outer stem seal or the entire stem housing assembly can be replaced while the valve is in line under pressure¹.

1.2 Outer Stem Seal Replacement Procedure

1.2.1 Perform the draining procedure as defined in III, 2. Valve must be in closed position

1.2.2 Remove the actuator and controls, taking care not to damage the stem or key. Remove the key retaining screw and key.

1.2.3 To insure that pressure is not trapped between the inner stem seal and the outer stem seal, vent the area using a 1/16" diameter rod to depress the ball check in the O.D. of the stem housing.

1.2.4 Using the appropriate socket, remove the eight (8) nuts retaining the adaptor plate while taking care not to damage the stem or adaptor plate alignment pin.

1.2.5 Remove the gland ring and outer stem seal.

1.2.6 Thoroughly lubricate the new stem seal and install.

1.2.7 Install the other components in the reverse order of the above.

1.3 Stem/Housing Repair Replacement Procedure¹.

1.3.1 Perform the Draining Procedure as defined in III, 2.

1.3.2 Remove the actuator and controls, taking care not to damage the stem or key. Remove the key retaining screw and key.

1.3.3 To insure that pressure is not trapped between the inner stem seal and the outer stem seal, vent the area using a 1/16" diameter rod to depress the ball check in the O.D. of the stem housing.

1.3.4 Using the appropriate socket, remove the eight (8) nuts retaining the adaptor plate. Remove the adaptor plate while taking care not to damage the stem or adapter plate alignment pin.

1.3.5 Remove the gland ring and outer stem seal.

1.3.6 Using the appropriate socket, remove the eight nuts retaining the stem housing.

1.3.7 Extract the stem/housing assembly from the body noting stem keyway and ball slot relationship.

1.3.8 Remove stem and seal from the stem housing.

1.3.9 Thoroughly clean all metallic components with a suitable solvent

1.3.10 Inspect all components for signs of wear or damage. Pay particular attention to sealing and bearing areas.

1.3.11 Replace all damaged or defective components.

Note: It is recommended that all seal components be replaced since defects cannot be readily determined by inspection.

¹ The entire stem/housing assembly can not be replaced while valve is under line pressure if the Ball-Trol valve was supplied with flow-ring seats (1/16" gap between seat and ball) or if the valve seats are badly damaged.

2. Major Overhaul

Major overhaul/replacement of internal components requires removal of the valve from the line.

2.1 Equipment Required

2.1.1 Lifting equipment suitable for the weight of the valve and components is required.

2.1.2 No special tools are required.

2.2 Disassembly

2.2.1 Turn the valve to half-open position and open the body vent valve to insure that there is no trapped pressure prior to removing the valve from the line.

2.2.2 Turn the valve to the closed position.

2.2.3 Remove the actuator and controls.

2.2.4 Remove the stem assembly according to procedure IV, 1.3.

2.2.5 Remove the body nuts, except for two nuts on each tailpiece, 180° apart.

2.2.6 Turn valve on end on an even, level surface with the tapped hole in the ball facing up, taking care not to damage the faces of the valve flange.

2.2.7 Remove the two nuts retaining the upper tailpiece and carefully lift tailpiece observing seat. Seat should remain with tailpiece. Do not allow seat to fall and damage ball.

2.2.8 Turn tailpiece over and place on even, level surface protecting end face.

2.2.9 Pry seat from tailpiece.

2.2.10 Remove the remaining nuts and lift body from assembly.

2.2.11 Install a lift eye in the tapped hole in the ball and lift the ball and bearing block assembly from the lower tailpiece. Place the ball/block assembly on appropriate blocks taking care not to damage the surface of the ball.

2.2.12 Pry the seat from the remaining tailpiece.

2.2.13 Seat disassembly (If applicable)

2.2.13.1 If the seat is welded design, no disassembly required.

2.2.13.2 If seat insert is retained by seat insert retainer ring, remove with screw driver.

2.3 Inspection and Replacement of Components

2.3.1 Thoroughly clean all metallic components with suitable solvent.

2.3.2 Inspect all components for signs of wear or damage. Pay particular attention to sealing and bearing areas.

2.3.3 Replace all damaged or defective components

2.3.4 It is recommended that all seal components be replaced since defects cannot be readily determined by inspection.

2.4 Lubrication and Preparation for Reassembly

2.4.1 Lubricate all moving metal contact surfaces such as seat pockets and stem housing.

2.4.2 Lightly lubricate all seals, gaskets, and thrust washers.

2.4.3 Reassemble seats, if required, as in 2.2.13 and install seat O.D. seal.

2.5 Reassembly

2.5.1 Place one tailpiece on a flat, level surface with the ball end up. Protect the end face.

- 2.5.2 Place the seat wave spring in position and install the seat.
- 2.5.2.1 Even force must be applied to install the seat ring in the tailpiece. (Do not use hammer.) On larger valves, the ball weight may be used by placing appropriate wood pieces on the seat face and lowering the ball onto the face.
- 2.5.3 While holding ball by previously installed lifteye, install thrust washers and bearing blocks, beveled side out. Rotate bearing block to assure free, smooth operation without binding and orient blocks vertically.
- 2.5.4 Install tailpiece seal over nose on tailpiece.
- 2.5.5 Lower ball/bearing block assembly onto Installed seat, carefully aligning dowel pins with holes in tailpiece face.
- 2.5.6 Lower the body over the ball, taking care not to damage seal angle on body or ball surfaces. Carefully align the stem hole in the body with the drive slot in the ball.

- 2.5.7 Install the stem assembly as described in IV, 1.3.
- 2.5.8 Install seat spring and seat in remaining tailpiece. Install body seal over nose on tailpiece. On larger valves, it may be necessary to place the seat assembly and spring on the ball and install the seat while lowering the tailpiece onto the body.
- 2.5.9 Lower the tailpiece onto the body, carefully aligning dowel holes in tailpiece with dowel pins in the bearing block. When lowering the tailpiece, insure that the seat ring does not fall and damage the ball.
- 2.5.10 Install all the body nuts and tighten both sides evenly.
- 2.5.11 Install body fittings.
- 2.5.12 Install operator and verify smooth operation of the valve and adjustment of the open/closed position stops.

ITEM	DESCRIPTION	QTY
A1	BODY STUDS	VAR
A2	BODY NUTS	VAR
A3	STEM HOUSING STUDS	VAR
A4	STEM HOUSING NUTS	VAR
B1	BODY	1
B2	TAILPIECE	2
B3	BEARING BLOCK	2
B4	STEM HOUSING	1
B5	BEARING	2 *
B6	DOWEL PIN (INT)	4 *
B7	DOWEL PIN (OTR)	1
B8	PIPE PLUG	1
B9	BODY VENT FITTING NOT SHOWN	1
B10	THRUST WASHER	2 *
B11	VENT FITTING	1
B12	COMPRESSION SPRING	1
O1	ADAPTER PLATE	1
O2	KEY	1
O3	S.H. CAPSCREW	1
S1	BODY O-RING	2 *
S2	SEAT INSERT	2 *
S3	SEAT O-RING	2 *
S4	STEM GASKET	1 *
S5	STEM HOUSING INR O-RING	1 *
S6	STEM HOUSING OTR O-RING	1 *
S7	STEM O-RING	2 *
S8	GLAND RING	1 *
T1	BALL	1
T2	STEM	1
T3	SEAT RING ONE PIECE	2
T4	INSERT RETAINER RING	2
T5	SEAT WAVE SPRING	2

* RECOMMENDED SPARE PARTS

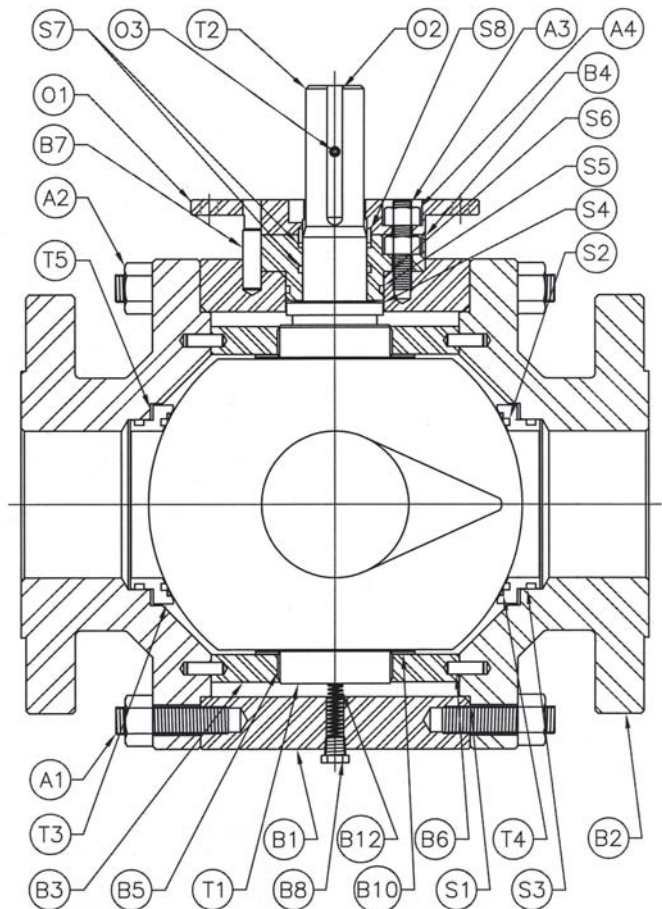

Notes



Your local contact:



SPX Flow Control
19191 Hempstead Hwy
Houston, TX 77065
Phone: (800) 231-3690 Fax: (281) 894-1332
E-mail: mjvalve@spx.com

For more information about our worldwide locations, approvals, certifications, and local representatives, please visit www.spxfc.com.

SPX Corporation reserves the right to incorporate our latest design and material changes without notice or obligation.

Design features, materials of construction and dimensional data, as described in this bulletin, are provided for your information only and should not be relied upon unless confirmed in writing.