

M&J VALVE

AN SPX BRAND

Installation, Operation & Maintenance Manual Piston Check Valve



M&J VALVE

AN SPX BRAND

M&J Valve

19191 Hempstead Highway

Houston, TX 77065

Telephone: 281-469-0550, Outside Texas (800) 231-3690

Fax: 281-894-1332

E-Mail: mjvalve@spx.com

Web Site: www.mandjvalve.com

SPX reserves the right to incorporate our latest design and material changes without notice or obligation. Design features, materials of construction and dimensional data, as described in this bulletin, are provided for your information only and should not be relied upon unless confirmed in writing.

Table of Contents

General Information.....	4
Installation	
Unpacking.....	4
Handling.....	4
Installation.....	4
Valve Operation.....	5
Maintenance.....	6
Piston Removal.....	6
Seat Removal.....	6
Seat Installation.....	8
Seat Locking Pin.....	8
Assembly.....	8
Engineering Data	
Weight Data.....	9
Parts List.....	10

Installation, Operation, and Maintenance Manual for M&J Piston Check Valves

I General Information

1. The M&J piston check valve provides back flow control for piping systems. Generally classified as “non slam”, it is designed specifically for use on the discharge of reciprocating compressors or any service with pulsating flow. It can also be used successfully in non-reciprocating service. The cast body design conforms to ANSI B16.34. Flanged end valve flanges are in accordance with ANSI B16.5 unless otherwise specified.
2. Carbon steel weld end valves have weld end connections that are readily field weldable. End preparations match specified mating pipe bores. Transition pieces are provided when specified.
3. Located on the valve cover plate, the nameplate (see detail below) provides applicable information including size, pressure class, materials, pressure/temperature, ratings and serial number. Provide the valve serial number when contacting M & J Valve Company in regards to your valve. This will expedite any request and insure that correct information is given. Note: The serial number is also stamped on the body near the cover plate joint.

M&J VALVE HOUSTON, TEXAS				
SIZE	CLASS	MODEL	API	F/F
BODY	GATE	SEAT	STEM	SEAL
TEMP MOP				CHARPY TEMP
DATE MFG	LICENSE NO	SERIAL NUMBER		

II Installation

1. Unpacking

- 1.1 All valves should be inspected on receipt for lost or damaged components.
- 1.2 Remove end connection protectors and thoroughly inspect valve interior for damage and/or foreign material. Remove all shipping supports.
- 1.3 Install all loose items as soon as possible to prevent loss or damage.

2. Handling

- 2.1 Small valves may be lifted with slings, straps, or by hooking into end flanges. Large valves are furnished with lifting eyes in the cover plate.

Caution:



Always use handling equipment that is suitable for the valve weight. Follow good lifting practices. Take care not to damage valve or component assemblies.

3. Installation

M & J piston check valves are designed for horizontal service. Valve sizes 4” and smaller may be mounted in a vertical position provided that they are equipped with a piston spring. When vertical flow is intended, valves must be specifically ordered for that service.

- 3.1 For horizontal service, valves should be installed with the inlet and outlet at the same level. The cover plate should be facing upward to allow proper piston action. The arrow on the body must be pointing in the direction of intended flow. For vertical flow up or down service, (4” valve size and smaller) install the check valve with the flow arrow pointing in the correct direction.
- 3.2 Clean the end connections and mating pipe prior to valve installation. It is recommended that the valve be supported properly to prevent strain and fatigue of the end connections.
- 3.3 Standard A and B trim valves with an ANSI rating of 150-1500 should be limited to 650° F service.

API valve models 2000 - 10,000 and ANSI 2500# are limited to 250° F due the presence of a Nitrile seal above the liner. For service temperatures higher than 650° F, check with M & J Valve for trim options and availability. NOTE: Working pressure ratings will be reduced for higher operating temperatures. See ASME B16.34 for pressure/temperature ratings based on material type.

3.4 For installation in centrifugal gas pump or compressor service, M&J Valve recommends that

all valves up to 8" size be equipped with a spring to help insure fast closing. Notify M&J Valve at time of order to insure correct application. When discharging into a pressurized system, The M & J Piston Check Valve should be installed downstream of the unit block valve. This will insure positive checking of backflow under start up conditions.

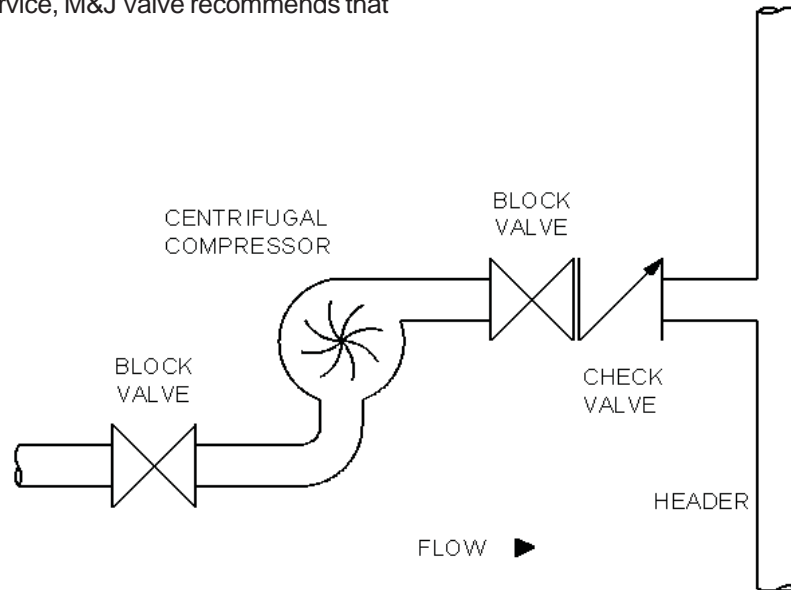

Installation Diagram for Centrifugal Gas Pump or Compressor System with Pressurized Discharge

III Valve Operation

The M & J Piston Check Valve has an internal piston that moves inside of a sleeve (liner). It is supported by piston rings that are similar to those used on automotive pistons. This piston has a tapered metal seal area that seats against a removable metal seat that is threaded into the valve body.

As upstream pressure and flow become greater than downstream pressure, the piston begins to lift off of the seat and slide up into the liner. When this occurs, the fluid in the chamber on top of the piston begins to compress. This compressed fluid would prohibit further lifting of the piston if there were not ball check valves installed in the top of it. These small spring loaded check valves are forced open by the compressing fluid trapped above the piston. As they open, fluid is allowed to escape letting the piston continue to travel upward. Once the driving force of the compressor "pulse" equalizes, the piston stops

rising and the ball checks close. This again seals off the area above the piston. At this time, gravity and/or a spring begin to push the piston back down towards the seat. As the piston begins to travel down, the area above it increases and a vacuum could form that would stop its descent. To avoid this situation, an orifice plug has been installed in the top of the piston. This part has a small hole through it that opens into the fluid flow path. Its purpose is to allow fluid to meter into the chamber above the piston letting it descend slowly. This creates a dampening effect that prevents the piston from slamming against the seat. Normally, before the piston contacts the seat, the next pulse enters the valve starting the whole cycle over. When flow stops, the piston will then contact the seat and any backflow pressure forces the piston seal surface tightly against the seat, preventing reverse flow.

IV Maintenance

4. Maintenance

M & J piston check valves require minimal maintenance. Under normal operating conditions, no periodic maintenance is necessary. Recommended spare parts available through M & J Valve Company consist of piston, piston rings, cover seals, ball check, orifice plug, and seat.

When ordering spare parts, specify the valve serial number, valve size, ANSI pressure class, and type of service.

Inspection and Repair

Caution: **Body pressure MUST be relieved before any attempt is made to service internal parts of the piston check valve. Follow all safety procedures and appropriate regulations for handling the pipeline media.**



4.1 Remove the valve cover plate. Remove and inspect the cover seal replacing if damaged or showing excessive set. NOTE: M & J Valve recommends that the cover seal be replaced each time the cover is removed.

4.2 Piston removal.

1" 2500#

4.2.1 Remove the liner locking plug and the liner hold down plug. Both pieces are screwed into the body. Clean and inspect.

4.2.2 Remove and inspect spring if present and replace if required.

4.2.3 Remove piston by threading a cap screw, threaded rod, or lifting eye into the tapped hole in top of piston. Use it to pull the piston out of the valve. NOTE: Thread size varies by piston size.

4.2.3 Clean and inspect piston, piston rings, and liner. Check piston seat area for damage or uneven wear. Replace if required. Insure that ball check works properly and that orifice hole is not clogged by debris

All other sizes

4.2.1 Remove piston by threading a cap screw or threaded rod into the tapped hole in top of the piston. Use it to pull the piston out of the valve. NOTE: Thread size varies by piston size.

4.2.2 Clean and inspect piston, piston rings, and liner. Check piston seat area for damage or uneven wear. Replace if required. Insure that ball check valves work properly and that the orifice hole is not clogged by debris

4.2.3 After removing piston, inspect seal area on both piston and seat for damage. Also check condition of piston rings and liner I.D. for excessive scratches or scoring.

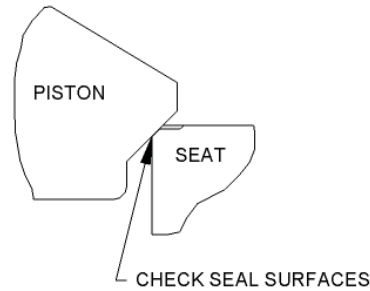

4.3 Seat removal.

4.3.1 Remove Liner by pulling out of valve body. Make sure that seat locking pin is saved.

4.3.1 All Piston Check Valve seats are threaded into the valve body. To facilitate installation and removal, each seat has a slot across the threaded end for engagement with a M&J Valve seat removal tool. An example of this tool with a seat ring engaged is shown below.

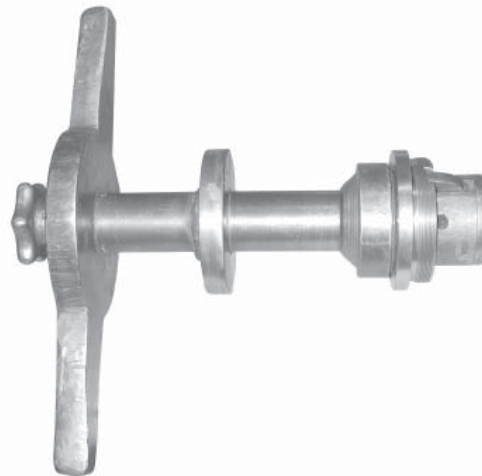

Typical Seat Removal Tool 1" - 4"
except high pressure with Seat Ring Installed

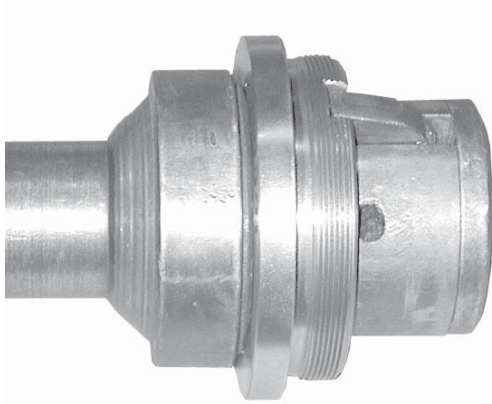

Enlarged Detail of Seat Removal Tool Showing Seat Ring Engaged

1" through 4"

4.3.2 Locate slots in seat ring. Insert seat removal tool into seat area. Head of seat removal tool should rest against top of seat. Retracted ears of seat removal tool should line up with slots in seat. Engage ears of seat removal tool with seat by turning knob on top of tool.

6" and larger and 1" - 3" high pressure

4.3.3 Holding seat clamp (bar with tapped holes) at an angle, lower through the seat bore. Once past the seat, pull the seat clamp up into slots located on the bottom of the seat ring. Temporarily hold in place.

NOTE: Engage both slots equally with seat clamp.

Seat Removal Tool Chart
(Contact M&J Valve for sizes not listed)

Size	Series	Part Number
1"	300, 600 & 2500	1-203-50-010
1-1/2"	150, 600, & 2500	1-203-50-020
2"	150-2500	1-203-50-030
2"	10,000	1-203-50-035
3"	150-2500, 2000-5000	1-203-50-040
3"	10,000	1-203-50-045
4"	150-2500, 2000-5000	1-203-50-050
4"	10,000	1-203-50-055
6"	150-2500, 2000-5000	1-203-50-060
8"	150-1500	1-203-50-070
10"	150-1500	1-203-50-080

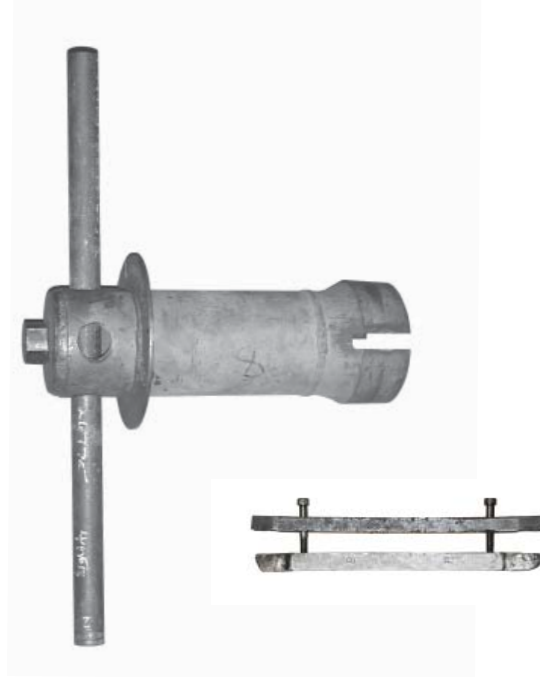

Typical Seat Removal Tool 6" and larger and 1"-3" high pressure

4.3.4 Set T-bar on top of seat. Using cap screws, attach T-bar to seat clamp. Tighten cap screws to lock seat, T-bar and seat clamp together into an assembly.

4.3.5 Locate seat clamp assembly on seat ring. Insert seat removal tool into seat area engaging seat clamp assembly in the slots provided.

4.3.6 With T-bar and seat clamp engaged in tool slots, turn handle counterclockwise to remove seat. NOTE: Seat may be difficult to remove on valves that have been in service for some time. Additional force may be required to break seat free.

4.3.7 Clean and inspect seat, Check seat seal area for damage or uneven wear. Replace if required.

4.4 Seat Installation

4.4.1 Before installing seat ring, clean threads in body and apply Bostik "Never Seize" regular grade anti-seize compound or equal that meets Mil Spec. 907E.

4.4.2 With tool ears engaged in seat ring slots carefully start seat threads in valve body and turn handle clockwise to install seat. Seat is completely installed when the underside of the seat flange contacts the body.

4.4.3 Remove seat tool.

4.4.4 If existing seat is being reinstalled, check to see if seat lock pin hole between body and seat match after installation. If it does, continue assembly and go to section 4.5.

4.4.5 After seat installation, drill hole for seat lock pin. Hole should engage both seat and body simultaneously. Use 3/16" drill for valve sizes up to 4", use 1/4" drill for valve sizes larger than 4", making hole 1/4" deep.

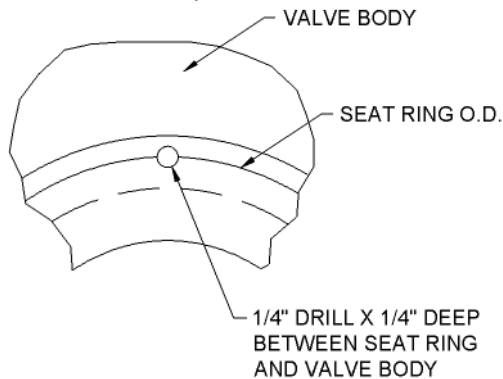

4.5 Seat Locking Pin

4.5.1 The seat locking pin prevents the seat from loosening and helps to tie the seat and liner together. If a new pin is being used bend pin as shown below before installing. Flats are between 3/8" and 3/4" long and angle can be 15 to 30 degrees.



Seat Locking Pin

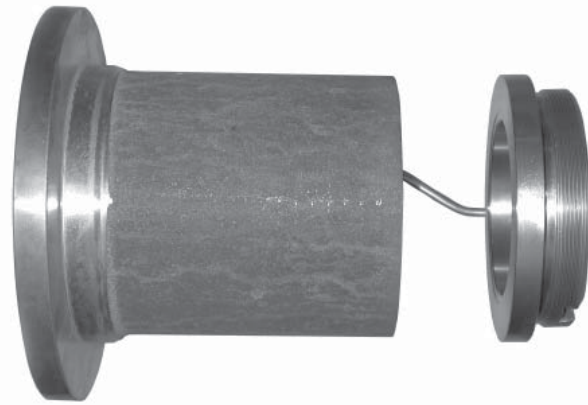

Seat Locking Pin Shown Installed in Seat and Liner
(Valve Body Not Shown)

4.6 Assembly

4.6.1 If required, install seat per section 4.4.

4.6.2 Insert one end of seat locking pin into 1/4" drilled hole. Position pin to accept hole in liner.

4.6.3 Insert liner into body insuring that the seat locking pin engages hole in bottom of liner. NOTE: Check gasket configuration before installing liner. There are four possible designs: 1) sheet gasket above the liner, 2) sheet gasket above and below the liner, 3) ring type joint gasket with rubber inner seal/spacer, and 4) for 6" 2500# only ring type joint gasket without a rubber gasket with four liner hold down screws. Install liner/ cover seal as required by valve gasket configuration.

4.6.4 Place piston rings on piston if they have been removed or are being replaced. Place the piston into the liner. NOTE: piston to seat seal is metal to metal and to seat the piston correctly may require several heavy taps to the top of the piston coining the piston and seat together. In some cases lapping the two seal surfaces together may be required.

4.6.5 Install liner/cover gasket/gaskets as required.

4.6.6 Install cover using studs and nuts and torque bolts.

Weights

Valve Size	ANSI Class	Weight (lbs.)
	150	43
	300	45
1	600	50
	900	100
	1500	110
	2500	130
	150	76
	300	78
1-1/2	600	80
	900	115
	1500	115
	2500	145
	150	78
	300	80
2	600	85
	900	135
	1500	145
	2500	170
	150	150
	300	155
3	600	175
	900	235
	1500	295
	2500	435
	150	240
	300	250
4	600	290
	900	335
	1500	480
	2500	730
	150	400
	300	415
6	600	550
	900	790
	1500	940
	2500	1865
	150	730
	300	750
8	600	810
	900	1950
	1500	1835
	2500	3500
	150	1275
	300	1300
10	600	1650
	900	1950
	1500	3620
	2500	4380

Valve Size	ANSI Class	Weight (lbs.)
	150	1630
	300	1660
12	600	2450
	900	2800
	1500	5100
	2500	14,000
	150	2450
	300	2500
14	600	2900
	900	N/A
	1500	6450
	2500	N/A
	150	3040
	300	3100
16	600	3700
	900	N/A
	1500	N/A
	2500	N/A
	150	N/A
	300	N/A
18	600	4600
	900	N/A
	1500	N/A
	2500	N/A
	150	N/A
	300	N/A
20	600	7900
	900	N/A
	1500	N/A
	2500	N/A
	2000	80
1-13/16	3000	125
	5000	135
	10,000	162
	2000	85
2-1/16	3000	135
	5000	145
	10,000	170
	2000	165
2-9/16	3000	220
	5000	235
	10,000	397
	2000	175
3-1/16	3000	235
	5000	295
	10,000	442
	2000	290
4-1/16	3000	335
	5000	480
	10,000	707

IV Parts List

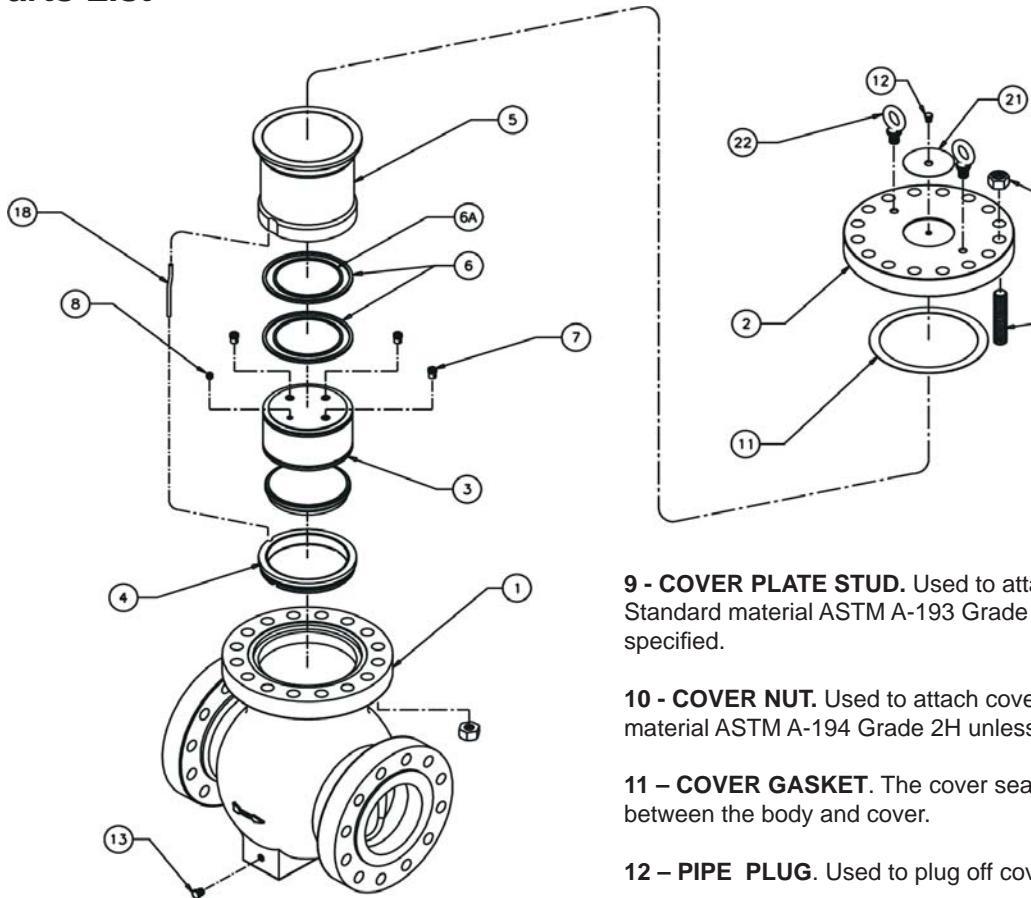

1 - BODY. The body is cast carbon steel unless otherwise specified. Top entry allows easy inspection and maintenance.

2 - COVER. The cover is made from carbon steel plate unless otherwise specified. Complete with ½"NPT port.

3 - PISTON. The piston seals against the seat preventing back flow. Made from a 400 series stainless steel unless otherwise specified. See Trim Chart.

4 - SEAT. Screws into the body and provides sealing area for piston. Made from a 400 series stainless steel unless otherwise specified. See Trim Chart.

5 - LINER. Provides replaceable sleeve for piston to travel in. Standard material is cast iron with hard chrome unless otherwise as specified. See Trim Chart.

6 - PISTON RINGS. Guides piston through liner. Standard material is cast iron. See Trim Chart.

6A - RING EXPANDERS. Only for use with Teflon® piston rings. Material is 316 stainless steel.

7 - BALL CHECK. Opens as Piston travels open to relieve upper piston cavity. Standard material is 316 stainless steel.

8 - ORIFICE PLUG. Allows media to fill piston cavity.

9 - COVER PLATE STUD. Used to attach cover to body. Standard material ASTM A-193 Grade B7 unless otherwise specified.

10 - COVER NUT. Used to attach cover to body. Standard material ASTM A-194 Grade 2H unless otherwise specified.

11 - COVER GASKET. The cover seal provides the seal between the body and cover.

12 - PIPE PLUG. Used to plug off cover port.

13 - PIPE PLUG. Used to plug off body drain.

14 - RING GASKET. (Not Shown) Replaces the cover gasket for class 2500# and higher valves.

15 - N/A.

16 - INTERNAL SEAL RING. (Not Shown) Used with ring gasket.

17 - PISTON SPRING. Used through 4" for vertical service and thorough 8" for liquid service.

18 - SEAT LOCKING PIN. Locks seat and liner in place. Made from 300 series stainless steel.

19 - LINER HOLD DOWN PLUG. (Not Shown, for 1" Class 2500# only) Stainless Steel.

20 - LINER LOCKING PLUG. (Not Shown, for 1" Class 2500# only) Stainless Steel.

21 - NAMEPLATE. Aluminum Casting or Stainless Steel.

22 - LIFTING EYE BOLTS. Steel.

23 - LINER HOLD DOWN SCREWS. (Not Shown, for Class 2500# only) Stainless Steel.

Notes



Your local contact:



SPX Flow Control
19191 Hempstead Hwy
Houston, TX 77065
Phone: (800) 231-3690 Fax: (281) 807-2829
E-mail: mjvalve@spx.com



For more information about our worldwide locations, approvals, certifications, and local representatives, please visit www.spxfc.com.

SPX Corporation reserves the right to incorporate our latest design and material changes without notice or obligation.

Design features, materials of construction and dimensional data, as described in this bulletin, are provided for your information only and should not be relied upon unless confirmed in writing.