

M&J VALVE

AN SPX BRAND

DANFLO Control Valves 400 Series Model 20

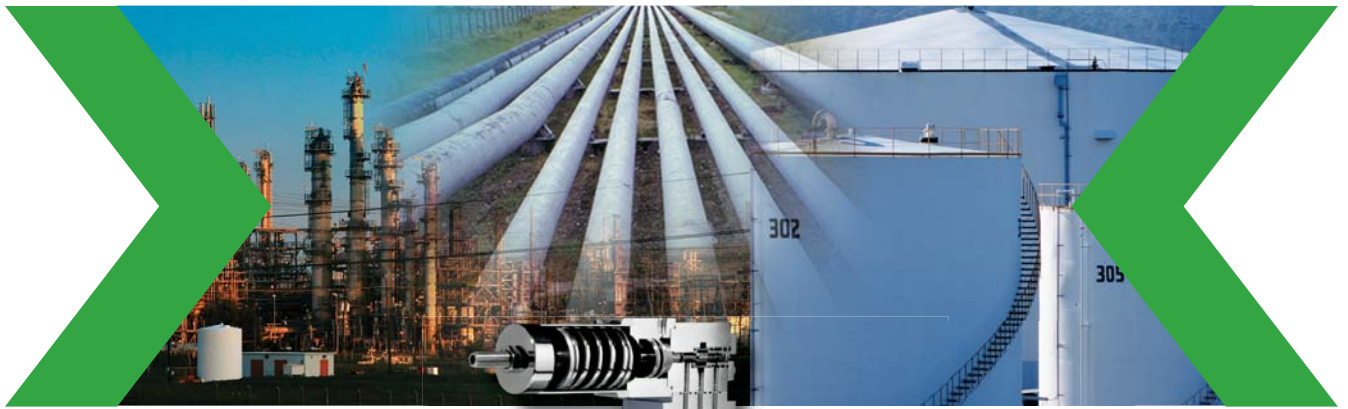

SPX[®]

Back Pressure/Pressure Relief

The DANFLO Model 20 is a pilot operated valve suitable for use in gas or liquid facilities and requires no outside power for operation. Pipeline pressure is the only power source required.

In BACK PRESSURE service, the Model 20 – a normally closed valve – will hold a minimum back pressure (upstream pressure) in a liquid pipeline facility, such as at a pump discharge or downstream of a flow meter to prevent the formation of gas bubbles in the liquid stream. Gas formation will occur when the pressure of the liquid flowing through the pump, meter, valve, etc., falls below its vapor pressure. The usual consequence of gas formation is cavitation which will result in excessive noise, damage to equipment, and incorrect flow measurement. The set pressure of the Danflo is whatever is necessary to keep the liquid pressure above its vapor pressure at that particular location in the system.

In PRESSURE RELIEF service, the Model 20 is used to prevent overpressure at its location in a liquid or gas piping system. The valve is normally closed and the pressure at which the valve begins to open is the relief set pressure.

Principle of Operation

The 400 Series Model 20 DANFLO valve consists of a dynamically balanced plug positioned to move axially along the valve centerline parallel to the flow, resulting in a low noise, high capacity streamlined flow path. By controlling the plug movement, flow through the annulus (space between plug and body) is regulated to maintain set point.

The sequence of operation is illustrated in Figures 1 and 2. The valve ports are identified as follows:

P_U = Pressure upstream (back pressure)

P_C = Pressure in plug cavity

P_D = Pressure downstream

The plug position is controlled by a 3-way modulating pilot which throttles the plug cavity pressure P_C , by allowing this pressure to increase or decrease depending on the sense line pressure.

When P_U is connected to P_C (Fig 1), upstream pressure (P_U) is routed into the plug cavity (P_C) causing the valve to close against a soft seat for an ANSI/FCI 70.2 Class V shutoff. When the pilot shuttles to the opposite position (Fig 2), P_C is connected to P_D and the cavity pressure P_C is vented to the vena contracta (lowest pressure area within the valve) causing the valve to throttle open.

Example of valve action assuming a pilot set point of 100 psig

- When upstream pressure is under 100 psig, valve closes (Fig 1)
- When upstream pressure is 100 psig or above, valve throttles open (Fig 2)

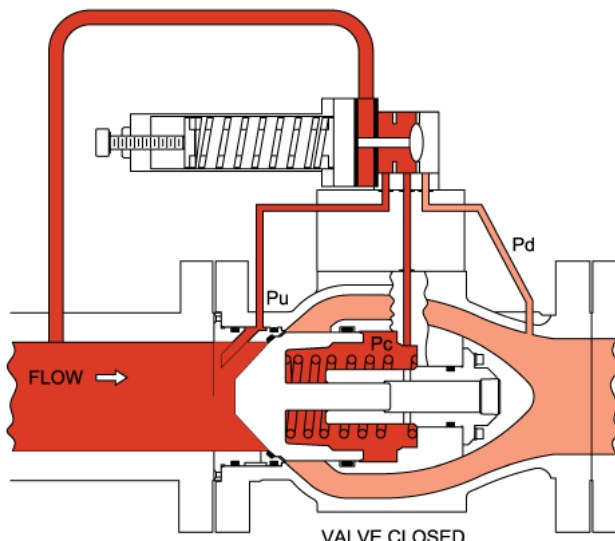

Figure 1

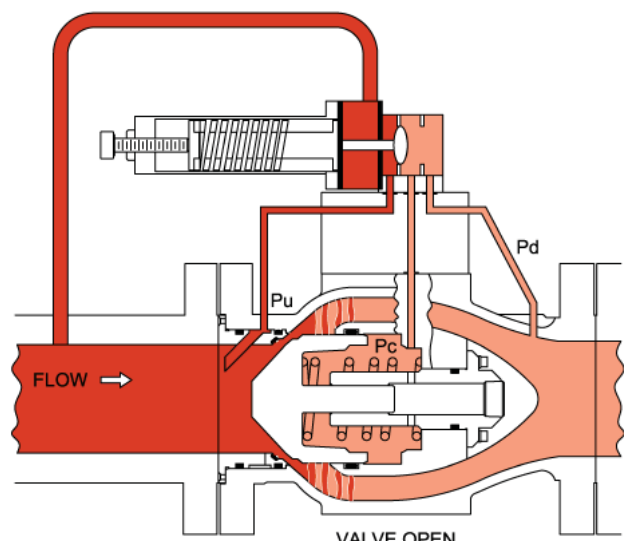

Figure 2

Service	Trim No.	Body Material(1)	Metal Trim Components						Seats & Seal		Manifold	Pilot Materials	
			Plug	Retainer	Seat Ring	Guide Sleeve	Spring	Internal Bolting	Seat	O-Rings	Block	Body	O-Rings
Non-Corrosive Service -20 to 400 F	A	ASTM A-216 WCC	ASTM A-216 WCC (ENP)(2)	ASTM A-216 WCC (ENP)	316 SS	ASTM A-216 WCC/ Impreglon I.D.	Chromium Vanadium (Alloy Steel)	18-8 SS					
Non-Corrosive Service Low Temp -50 to 240 F	B	ASTM A-352 LCC	ASTM A-352 LCC (ENP)	ASTM A-352 LCC (ENP)	316 SS	ASTM A-352 LCC/ Impreglon I.D.	17-4PH SS	18-8 SS	Standard: Nylon	Available Choices: Viton A Viton GFLT, Buna-N (Nitrile), EPDM, LT-Buna-N	316 SST	316 SST	Available Choices: Viton A, Viton GFLT, Buna-N (Nitrile), EPDM, LT-Buna-N
Mild-Corrosive Service -20 to 400 F NACE MR0175(3)	AN	ASTM A-216 WCC	ASTM A-216 WCC (ENP)	ASTM A-216 WCC (ENP)	316 SS	ASTM A-216 WCC/ Impreglon I.D.	17-4PH SS	18-8 SS	Available: Viton A, Viton GFLT, Buna-N, EPDM, LT-Buna-N				
Mild-Corrosive Service Low Temp. -50 to 240 F NACE MR0175	BN	ASTM A-352 LCC	ASTM A-352 LCC (ENP)	ASTM A-352 LCC (ENP)	316 SS	ASTM A-352 LCC/ Impreglon I.D.	17-4PH SS	18-8 SS					
Corrosive Service -20 to 400 F	E	ASTM A-216 WCC (ENP)	17-4PH SS	17-4PH SS	316 SS	17-4PH SS/ Impreglon I.D.	Inconel X750	18-8 SS					

(1) Other body materials are available upon request

(2) ENP-Electroless Nickel Plated

(3) NACE Trim meets MR01-75 Latest Edition

Ordering Guide

Because of the many variations available in the DANFLO valve line, it is important that the factory know as much as possible about the intended installation, including:

- Line size and pipe schedule
- Pressure rating
- Maximum line pressure (Inlet & Outlet)
- Max/min differential pressures
- Max/min line-media temperatures
- Max/min line flow rates
- Composition of line media
- Specific gravity of media
- Vapor pressure of media
- Batch or Continuous operation
- Operational mode and type control device to be used (pilot, N2 loaded, etc.)
- Cavitation trim needed
- Special considerations

Typical Applications: Back Pressure/Pressure Relief

A. Model 20 DANFLO installed at the bottom of a hill. In this application, the Model 20 maintains a back pressure equal to the head pressure created by the incline to prevent liquid separation. Locate the sense line connection 10 pipe diameters from the upstream flange of the control valve.

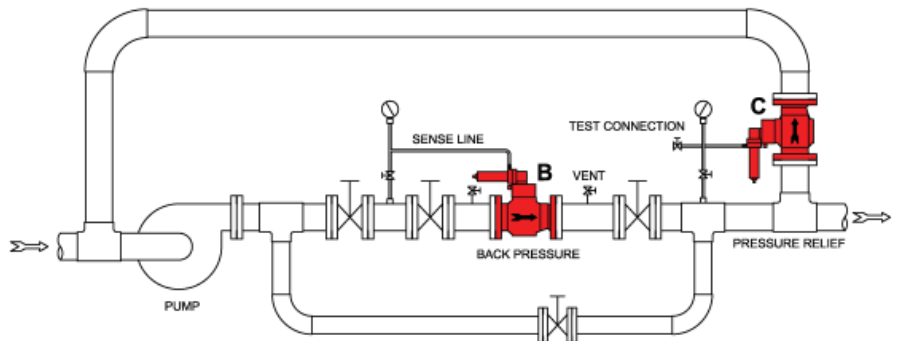

B. Model 20 DANFLO in Back Pressure Service maintaining a minimum pressure against a pump discharge for more efficient operation of the pump.

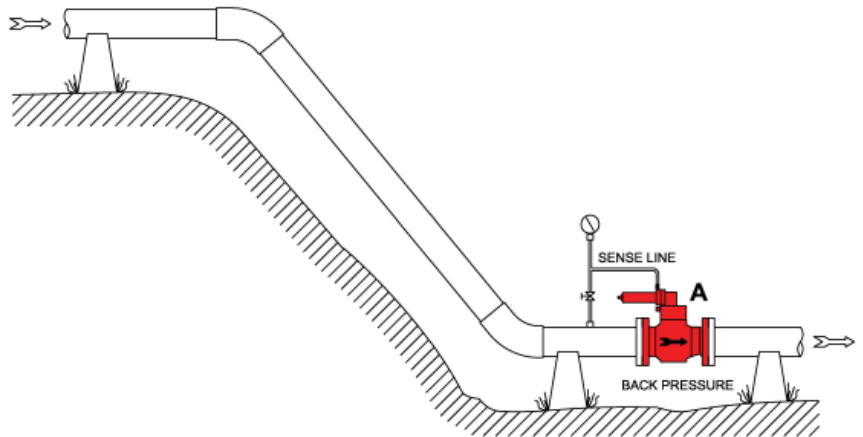

C. To protect the downstream piping install a Model 20 DANFLO as a Pressure Relief Valve. In liquid applications, the valve outlet is piped to pump suction as shown, to storage, or to a sump.

Pilot Spring Range Options

Pilot Size	Spring Range Psig	Spring Range MPag	Spring Range Barg
10 GPM	25-80	0.17-0.55	1.7-5.5
10 GPM	70-200	0.48-1.38	4.8-13.8
10 GPM	200-600	1.38-4.14	13.8-41.4
10 GPM	500-1000	3.45-6.89	34.5-68.9
10 GPM	800-1250	5.52-8.62	55.2-86.2
10 GPM	1250-1500	8.62-10.34	86.2-103.4
10 GPM	1450-2200	10-15.17	100-151.7
25GPM	25-75	0.17-0.52	1.7-5.2
25GPM	60-150	0.41-1.03	4.1-10.3
25GPM	135-300	0.93-2.07	9.3-20.7
25GPM	275-500	1.9-3.45	19.0-34.5
25GPM	450-800	3.1-5.52	31.0-55.2
25GPM	750-1500	5.17-10.34	51.7-103.4
75 GPM	25-75	0.17-0.52	1.7-5.2
75 GPM	60-160	0.41-1.1	4.1-11.0
75 GPM	145-300	1.0-2.07	10.0-20.7
75 GPM	275-500	1.9-3.45	19.0-34.5
75 GPM	450-800	3.1-5.52	31.0-55.2
75 GPM	750-1300	5.17-8.97	51.7-89.6

Note:

2" - 6" Danflo valves uses 10 GPM pilot

8"-10" Danflo valve uses 25 GPM pilot

12" & 16" Danflo valves use 75 GPM pilot

Filter

All Model 20 DANFLO valves come with a 316 SST (housing & filter material) filter that is flush mounted to the pilot manifold block. Filter mesh size is 140 Micron.

Soft Goods-Temperature Limits

Soft Good	Min Deg°F	Max Deg°F	Min Deg°C	Max Deg°C
Viton A	0	400	-18	204
Buna-N (Nitrile)	-20	250	-29	121
EPDM	-40	400	-40	204
Viton-GFLT	-20	300	-29	149
Buna-N LT	-65	225	-54	107
Nylon	-60	250	-51	121

MAXIMUM VALVE Cv for delta-P ≥ 25 psi

Valve Size (Inch)	DIN (mm)	Standard Trim	Cav 1-Stage	Cav 2-Stage
2"	50	120	40	30
3"	75	330	80	60
4"	100	480	159	115
6"	150	1200	400	225
8"	200	1900	700	600
10"	250	3100	1200	1000
12"	300	4200	2800	2500
16"	400	7630	3300	3000

Note: Since the Danflo has large capacity, our Danflo design minimizes the selected valve size and allows same size refits to existing installations with an overall capacity increase.

Optional Equipment

- Field Test kit. Allows for set point verification with valve installed in the pipeline.
- Speed control valve(s) can be supplied to dampen the pilot response to pressure changes.

Note: Speed control valves are not recommended for pressure relief services.

Danflo Nameplate

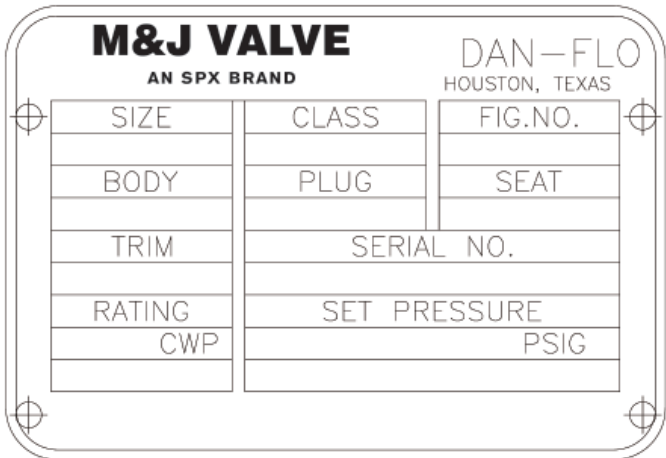

Approximate Shipping Weight & Dimensions

Size		Shipping Cube	Weight
2"	300#	0.92 Cu. Ft. (0.026 M ³)	80 Lbs. (36 Kg.)
	600#	1.01 Cu. Ft. (0.029 M ³)	86 Lbs. (39 Kg.)
	900#	1.02 Cu. Ft. (0.029 M ³)	125 Lbs. (57 Kg.)
3"	300#	1.27 Cu. Ft. (0.036 M ³)	123 Lbs. (55 Kg.)
	600#	1.35 Cu. Ft. (0.038 M ³)	129 Lbs. (58 Kg.)
4"	300#	1.57 Cu. Ft. (0.045 M ³)	154 Lbs. (70 Kg.)
	600#	1.88 Cu. Ft. (0.053 M ³)	180 Lbs. (81 Kg.)
	900#	2.24 Cu. Ft. (0.063 M ³)	420 Lbs. (190 Kg.)
6"	300#	3.01 Cu. Ft. (0.085 M ³)	368 Lbs. (167 Kg.)
	600#	3.32 Cu. Ft. (0.094 M ³)	412 Lbs. (187 Kg.)
	900#	3.78 Cu. Ft. (0.107 M ³)	650 Lbs. (295 Kg.)
8"	300#	5.42 Cu. Ft. (0.153 M ³)	560 Lbs. (254 Kg.)
	600#	5.74 Cu. Ft. (0.163 M ³)	630 Lbs. (286 Kg.)
10"	300#	9.43 Cu. Ft. (0.267 M ³)	970 Lbs. (440 Kg.)
	600#	9.49 Cu. Ft. (0.269 M ³)	1100 Lbs. (500 Kg.)
12"	300#	14.45 Cu. Ft. (0.409 M ³)	1625 Lbs. (737 Kg.)
	600#	17.36 Cu. Ft. (0.492 M ³)	1820 Lbs. (825 Kg.)
16"	150#	25.61 Cu. Ft. (0.725 M ³)	4500 Lbs. (2041 Kg.)
	300#	25.61 Cu. Ft. (0.725 M ³)	4500 Lbs. (2041 Kg.)
	600#	26.0 Cu. Ft. (0.736 M ³)	4500 Lbs. (2041 Kg.)
	900#	27.54 Cu. Ft. (0.780 M ³)	5000 Lbs. (2268 Kg.)

Dimensions for Surge Relief Valves

Valve Size (in)	DIN (mm)	ANSI	A In (mm)	B In (mm)	C In (mm)
2"	50	150	11.5 (292)	10.31 (262)	13.56 (345)
		300	11.5 (292)	10.31 (262)	13.56 (345)
		600	11.5 (292)	10.81 (275)	14.06 (357)
		900	12.5 (318)	9.94 (252)	14.19 (360)
3"	75	150	12.5 (318)	11.38 (289)	15.5 (394)
		300	12.5 (318)	11.38 (289)	15.5 (394)
		600	13.25 (337)	11.38 (289)	15.5 (394)
4"	100	150	13.938 (354)	11.88 (302)	16.38 (416)
		300	13.938 (354)	11.88 (302)	16.38 (416)
		600	15.0 (381)	12.25 (311)	17.63 (448)
		900	17.57 (446)	12.25 (311)	18.0 (457)
6"	150	150	17.75 (451)	14.19 (360)	20.63 (524)
		300	17.75 (451)	14.19 (360)	20.63 (524)
		600	19.125 (486)	14.19 (360)	21.19 (538)
		900	20.75 (527)	14.38 (365)	21.88 (556)
8"	200	150	22.25 (565)	16.67 (423)	24.67 (626)
		300	22.25 (565)	16.91 (429)	24.91 (633)
		600	23.75 (603)	16.67 (423)	25.04 (636)
10"	250	150	30.125 (765)	18.79 (477)	28.79 (731)
		300	30.125 (765)	18.79 (477)	28.79 (731)
		600	30.313 (770)	18.79 (477)	28.79 (731)
		900	32.0 (813)	18.85 (479)	29.61 (752)
12"	300	150	35.0 (889)	21.38 (543)	33.38 (848)
		300	35.0 (889)	21.38 (543)	33.38 (848)
		600	36.75 (933)	22.75 (578)	35.88 (911)
		900	36.75 (933)	22.75 (578)	35.88 (911)
16"	400	150	44.5 (1130)	24.63 (626)	40.38 (1026)
		300	44.5 (1130)	24.63 (626)	40.38 (1026)
		600	44.5 (1130)	24.88 (632)	40.58 (1031)
		900	45.0 (1143)	25.32 (643)	41.76 (1061)

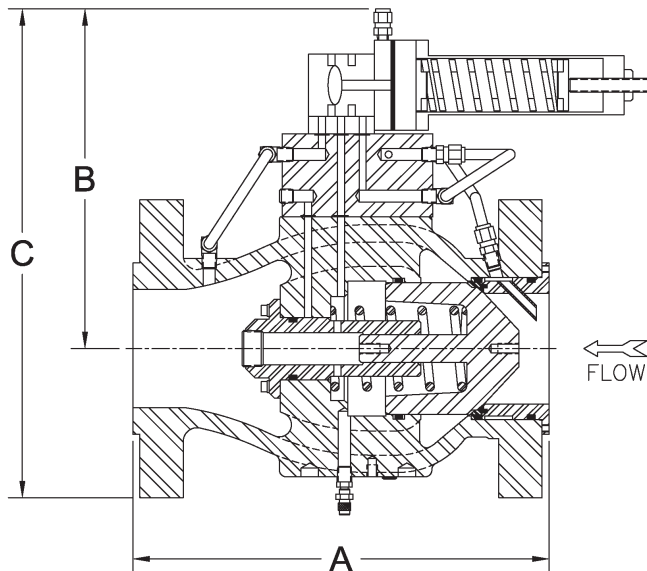

Control Valve Numbering System

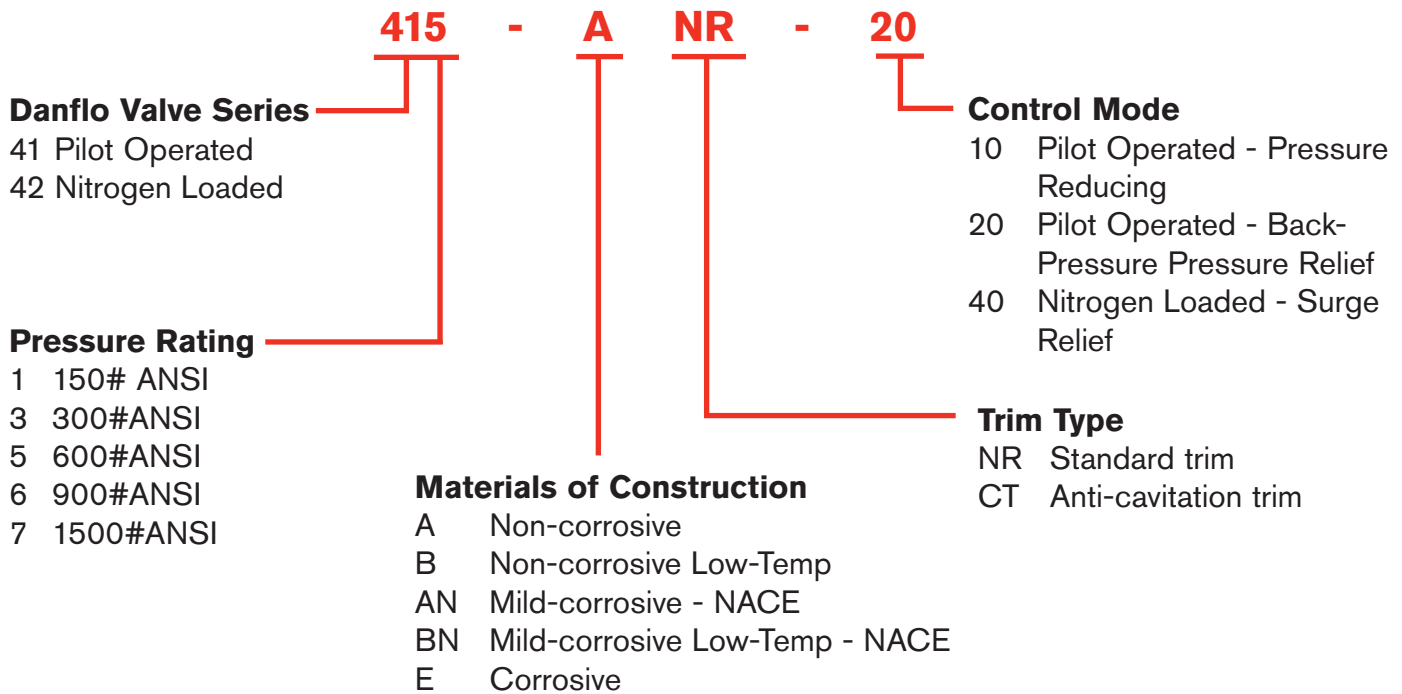

Your local contact:



M&J Valve, An SPX Brand
19191 Hempstead Hwy
Houston, TX 77065
Phone: (800) 231-3690 Fax: (281) 807-2829
E-mail: mjvalve@spx.com

For more information about our worldwide locations, approvals, certifications, and local representatives, please visit www.mandjvalve.com.

SPX Corporation reserves the right to incorporate our latest design and material changes without notice or obligation.

Design features, materials of construction and dimensional data, as described in this bulletin, are provided for your information only and should not be